



COMPETITORS INFORMATION No. 9

Date: August 30th, 2019

To All Competitors,

RE: TRACKING/ SCREAMER SYSTEM MOUNTING COMPONENTS

Please find attached the new tracking/ screamer system with the mounting template and wiring instructions. **It is imperative the instructions are followed precisely.**

A deposit of KShs 15,000 / US\$ 150 must be paid in cash only at the administrative check. Deposits are refunded in cash at sight when the equipment is returned to the organizer in working condition.

It is mandatory that each competitor have properly installed and working Tracking system (Tracker) on board of the rally vehicle and competitors are obliged to provide a power source for this tracking device as required by the Tracking Company. The fitting of antennas for GPRS and the GPS unit are compulsory. The system is installed by the organizer at Scrutineering.

The tracking devices will be dismantled by the organizer in the last Parc Ferme. If a crew retires the rally, they can dismantle the Tracking device without causing any damage to the hardware and return it to the HQ, where after checking of the condition of the device, the deposit will be refunded.

Pipi Renu
Rally Manager

East African Safari Rally Limited
P.O. Box 14910
Westlands 00800
Nairobi
Kenya
Tel: +254-20-4450030
Fax: +254-20-4450050
Email: info@eastafricansafarirally.com
Website: www.eastafricansafarirally.com



**RALLY SAFETY SYSTEM
INSTALLATION MANUAL**

SYSTEM COMPONENTS

- **GPS Tracker** - 73x73x27mm (WxHxD). Installed at the A-pillar roll-cage using cable ties or at the dashboard using double sided tape.
- **Com-box** - 73x73x27mm (WxHxD). Installed via slip and clip in the supplied metal Base / Mount bracket.
- **Base / Mount bracket** - 75x74x26mm (WxHxD). Installed on the dashboard by means of screws, cable ties or double sided tape.



The Base / Mount bracket is supplied by the Geotraq team at the administrative check and remains property of the competitor after the event.

POWER SUPPLY

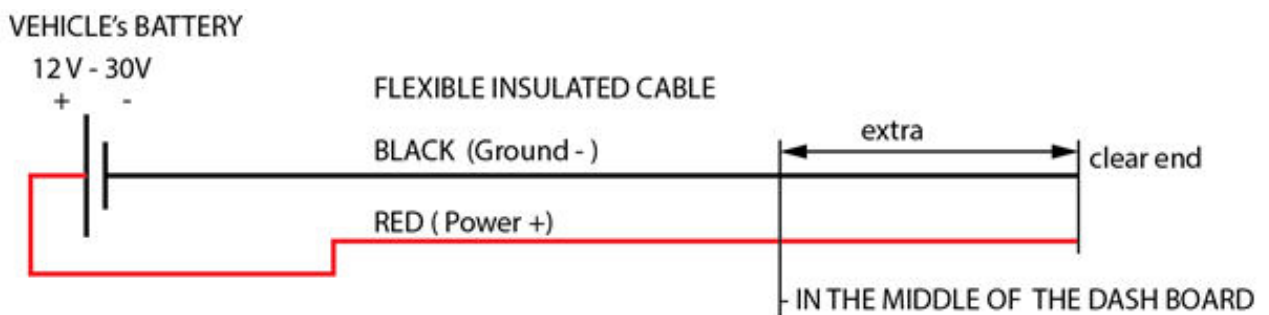

- The power cord must be connected directly to the battery. The Master cut-off (kill) switch must not interrupt the power supply to the system.
- The cabled used must be “flexible” (multi wire), insulated cable – 2x1 mm² or 2x1.5 mm² – Red and Black coloured (if possible).
- A 3A fuse (responsibility of the competitor) should be connected to the positive wire.

- The end of the power cord must be located as per the instructions at the top of the dash board or under it with easy access.
- The power cord must be prepared in advance and connected to the vehicle's battery when the vehicle is presented for scrutineering.
- Electrical details: voltage 6-30V DC, Nominal voltage 12V, Energy consumption (at 12.6V) 110 mA r.m.s.

Leave the power cord in place with at least 10 cm to spare for easy handling.

BASE / MOUNT BRACKET

- The Base / Mount bracket can be attached to the dashboard or to the roll-cage.
- The fitting can be done via screws, cable ties and double sided 3M tape. It is the responsibility of the competitor to prepare and mount the Base / Mount bracket before the vehicle is presented for scrutineering.

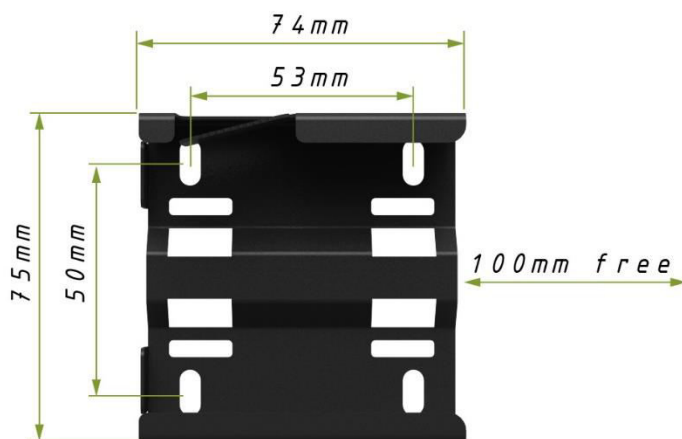

At least 10 cm of space must be left on the sliding side of the Base / Mount bracket to allow the installation of the Com-box.

POWER CONNECTORS

- The power cord must be equipped with FULLY INSULATED FEMALE Crimp Spade Terminal Connector – 6.3 x 0.8 mm. The Geotraq team will install the required terminals to the ready power cords.



INSTALLATION LOCATION

The Com-Box must be visible and accessible to the drivers even when they are sitting with the seatbelts buckled.

